



CORONA SECONDARY SCHOOL

AGBARA

A Culture of Excellence and Life-Long Learning

MIDTERM ASSIGNMENT FOR SECOND TERM 2022/2023

CLASS: YEAR 9

Contents

GENERAL INSTRUCTIONS 2

Submission Deadline 2

Questions..... 2

Rubrics 2

Teachers’ Contact Details 2

A. TECHNICAL DRAWING 3

B. BUSINESS STUDIES..... 4

C. RELIGIOUS STUDIES 4

Module: Christian Religious Studies 4

Module: Islamic Religious Studies 5

D. PHYSICAL AND HEALTH EDUCATION 5

E. HOME ECONOMICS 6

F. HISTORY 7

GENERAL INSTRUCTIONS

Submission Deadline

All assignments will be submitted on Thursday, 2nd March, 2023.

Questions

Students should note sections for each subject and read carefully:

- Individual subject content in focus.
- Questions and responses required.

Rubrics

Students should critically read rubrics as guides to know how scores are weighed.

Teachers' Contact Details

Your teachers' contact details are provided for inquiries where needed.

A. TECHNICAL DRAWING

Instruction: Assignment should be done on a drawing sheet.

Visualize the given shape and then answer the following questions:

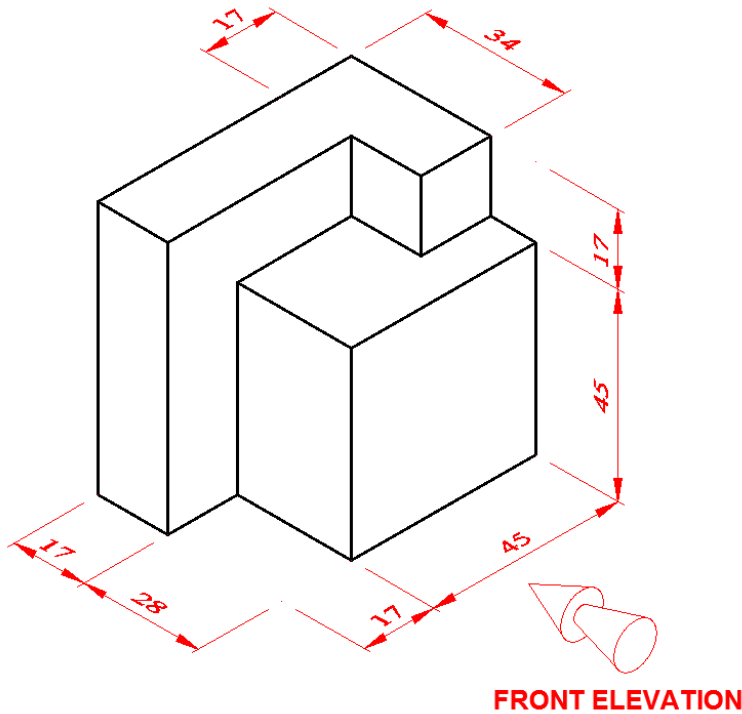

1. Construct the isometric view of the given shape. [8]
2. Construct the orthographic view of the shape in third angle. [12]

RUBRICS:

| | |
|--|-----|
| For the draughtsmanship of the isometric shape | [3] |
| For the accuracy of the isometric shape | [5] |
| For the front elevation of orthographic view | [4] |
| For the side elevation of orthographic view | [4] |
| For the plan of the orthographic view | [4] |

Total: 20 marks

Teacher's Contact Details

- Mustapha Olaniyan
- E-mail: Mustapha.Olaniyan@coronaschools.org
- **Mobile:** +234-703-611-7665

B. BUSINESS STUDIES

Instruction: The financial planning of every organization goes a long way in determining the survival of the business. Surviving organizations must keep financial records.

RUBRICS

1. What are financial records of an organization? [3]
2. What are the benefits of good financial record keeping. List five (5). [5]
3. Discuss at least three (3) implications of not keeping proper financial record. [6]
4. What is 'budget'? [2]
5. List four (4) benefit of a budget to individuals and organizations. [4]

Total: 20 marks

Teacher's Contact Details

- Nafiu Folasade
- Folasade.Nafiu@coronaschools.org
- Mobile: +234-808-238-5531

C. RELIGIOUS STUDIES

Module: Christian Religious Studies

Instruction: Do this work in your Test and Assignment notebook.

1. Explain the reason for Paul's appreciation of the Philippians in Philippians 4: 14-20. [3]
2. According to Paul, the gifts sent to him by the Philippians was described as a fragrance offering, a sacrifice acceptable and pleasing to God. What was Paul expressing in this verse? [4]
3. Paul in his letter to the Corinthians (2 Corinthians 8:1-5) gave an example of the Macedonians as giving during a time of affliction and in extreme poverty. This, he said has flowed in a wealth of liberality on their own part.
Explain briefly what Paul meant by this statement. [3]

4. 'For you know the grace of our Lord Jesus Christ, that though he was rich yet for your sake he became poor, so by his poverty, you might become rich' (2 Corinthians 8:9)

Explain what Paul meant by these words. [3]

5. 'The point is this: he who sows sparingly will reap sparingly and he who sows bountifully will also reap bountifully'. (2 Corinthians 9 v 6)

Explain what Paul meant in this passage [2]

Converted Total: 20 marks

Teacher's Contact Details

- Yemisi Ajayi
- E-mail: Yemisi.Ajayi@coronaschools.org
- Mobile: +234-816-559-3892

Module: Islamic Religious Studies

Instruction: The assignment should be written in the student's Test and Assignment notebook

1. What is sujudu sahwu? [2]
2. Mention and explain the types of sujudu sahwu. [8]
3. State and explain the conditions that warrant the performance of one of the sujudu sahwu. [5]
4. Mention the act of worship that cannot be corrected through sujudu sahwu. [5]

Total: 20 marks

Teacher's Contact Details

- Bello Yusuf Mohammed
- E-mail: Bello.Mohammed@coronaschools.org
- Mobile: +234-803-478-8175

D. PHYSICAL AND HEALTH EDUCATION

Instruction: Answer all questions

1. Justify the importance of photosynthesis to man. [5]
2. Explain the aerobics and anaerobic energy supply. [5]
3. Explain the three (3) types of games on cricket. [5]
4. Mention the three (3) anatomical planes and discuss two (2) [5]

Teacher's Contact Details

- Itandayo Adekale
- E-mail: Itandayo.Adekale@coronaschools.org
- Mobile: +234-810-235-7255

E. HOME ECONOMICS

Instruction: Food spoilage is undesirable changes that occur in food thereby making the food inedible.

RUBRICS

1. Highlight five factors that can be responsible for this? [5]
2. Discuss five sources of food contamination. [5]
3. Fill the table below with two signs of spoilage each. [10]

| S/N | FOOD ITEM | SIGNS OF SPOILAGE |
|-----|------------------|-------------------|
| 1. | Bread | |
| 2. | Fresh meat | |
| 3. | Fruits | |
| 4. | Leafy vegetables | |
| 5. | Fish | |

Total: 20 marks**Teacher's Contact Details**

- Busayo Shodiya
- E-mail: Busayo.Shodiya@coronaschools.org
- Mobile: +234-814-666-3754

F. HISTORY

Instruction: Answer all questions

1. What do you understand by amalgamation? [2]
2. Explain five reasons for amalgamation of Nigeria. [5]
3. Briefly explain the process of the amalgamation of the Nigerian territories. [5]
4. What roles did George Taubman Goldie play in the amalgamation of the Nigerian territories? [8]

Total: 20 marks

Teacher's Contact Details

- Solomon Owolabi
- E-mail: Solomon.Owolabi@coronaschools.org
- Mobile: +234-803-448-7090