



**CORONA SECONDARY SCHOOL
AGBARA**

END OF TERM CROSS CURRICULAR ASSIGNMENT FOR SECOND TERM, 2023/2024

CLASS: YEAR 10

Contents

| | |
|--|---|
| GENERAL INSTRUCTION..... | 2 |
| Submission Deadline | 2 |
| Questions | 2 |
| Rubrics | 2 |
| Teachers' Contact Details | 2 |
| PHYSICAL EDUCATION/TECHNICAL DRAWING..... | 3 |
| FRENCH/YORUBA LANGUAGE..... | 4 |
| GEOGRAPHY/PHOTOGRAPHY..... | 4 |
| DRAMA/GERMAN..... | 4 |
| FURTHER MATHEMATICS/GLOBAL PERSPECTIVE..... | 5 |
| HISTORY/CHRISTIAN RELIGIOUS STUDIES/ISLAMIC RELIGIOUS STUDIES..... | 5 |



**CORONA SECONDARY SCHOOL
AGBARA**

END OF TERM CROSS CURRICULAR ASSIGNMENT FOR SECOND TERM, 2023/2024

CLASS: YEAR 10

GENERAL INSTRUCTIONS

Submission Deadline

All assignments will be submitted on Monday, 15th April 2024.

Questions

Students should note sections for each subject and read carefully:

- Subject topic(s) in focus;
- Questions and responses required;

Rubrics

Students should critically read rubrics as guides to how scores are weighted.

Teachers' Contact Details

Your teacher's contact details are provided for inquiries where needed.

.....

DATE OF SUBMISSION: MONDAY, 15TH APRIL, 2024



**CORONA SECONDARY SCHOOL
AGBARA**

END OF TERM CROSS CURRICULAR ASSIGNMENT FOR SECOND TERM, 2023/2024

CLASS: YEAR 10

A. SUBJECT: PHYSICAL EDUCATION/TECHNICAL DRAWING.

Instruction: Your construction should be done on A3 paper or Carboard paper

- Use all the necessary drawing instruments and materials.
- All dimensions should be in millimeters(mm)

Detailed Measurements and Dimensions of a Handball Court

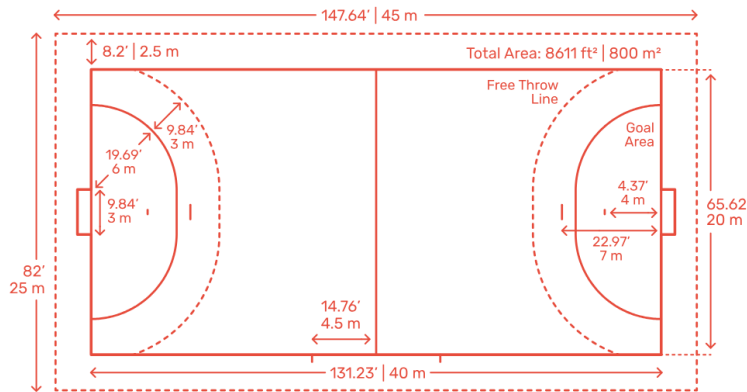

The handball court is 40 meters long and 20 meters wide and is equally divided by the center line. The goal is 3 meters wide and 2 meters in height. **Using a scale of 1cm to represent 1m**, construct a standard hand ball court and show the following:

1. **The Playing Field:** The playing field measures 40 meters by 20 meters.
2. **Half Line:** A half line (denoted as 'centre line' in the court diagram) divides the court into two equal halves.
3. **Free Throw Line:** A free throw line is marked in a near-semicircular manner. It is 9 meters away from the goal. If a foul is committed outside the goal area line, the offensive team gets a free throw. The free throw is supposed to be taken anywhere beyond this line. It is differentiated from the goal area line by dotting it; that is, it is not marked by a continuous line.
4. **Goal Area Line:** This is a line inside the free throw line. It is 6 meters away from the goal.
5. **Penalty Line:** This line is 7 meters away from the center of the goal.

Rubrics:

- | | |
|---|------------|
| • Accuracy | (7 marks) |
| • Draughtmanship | (3 marks) |
| • Indication of locations (2marks for each) | (10 marks) |

Total: 20marks

Name of teachers:

- | | |
|---------------------|-------------|
| • Mustapha Olaniyan | 07036117665 |
| • Sarah Jatto | 08056636520 |

Mustapha.Olaniyan@coronaschools.org
Sarah.Jatto@coronaschools.org



**CORONA SECONDARY SCHOOL
AGBARA**

END OF TERM CROSS CURRICULAR ASSIGNMENT FOR SECOND TERM, 2023/2024

CLASS: YEAR 10

B. SUBJECT: FRENCH LANGUAGE/YORUBA LANGUAGE

Instruction: Answer all questions in your test and assignment notebook.

Write a short note on each of the culture of French and Yoruba people on the following:

1. List 10 different types of food French and Yoruba people like. (10 marks)
2. Write out 5 modes of their dressing. (5 marks)
3. French and Yoruba people engage in trading, list 5 of such traditional trade they engage in to earn a living. (5 marks)

kindly support your write up with pictorial research evidence for items 1 – 3 and this must be written in both French and Yoruba.

Total 20marks

Name of teachers:

- | | | |
|-------------------|-------------|--|
| • Chigozie Obieke | 08062670533 | Chigozie.Obieke@coronaschools.org |
| • Idowu Durojaye | 07068581540 | Olusola.Durojaye@coronaschools.org |

C. SUBJECT: GEOGRAPHY/PHOTOGRAPHY

Instruction: Assignment should be spiral banded and submitted in copies of two. One to the Geography teacher and One to the Photography teacher. Photos and images should not be blurry.

1. Discuss extensively, how different geographical regions (with examples) offer unique opportunities for photographers in terms of capturing diverse landscapes, wildlife, and cultural experiences? (10 marks)
2. Tourists sometimes encounter challenges in navigating their way in new environments. Discuss how photographers utilize geographical knowledge to effectively plan and navigate through various terrains or environments in tourism? (10 marks)

Total: 20 marks

Name of teachers:

- | | | |
|----------------|-------------|--|
| • Assumpta Eze | 08066713510 | Assumpta.eze@coronaschools.org |
| • Clara Nzekwu | 08034376354 | Clara.Nzekwu@coronaschools.org |

D. SUBJECT: DRAMA/GERMAN

Instruction: You are to create your own word document to answer the questions. Save and title it as: *your first name surname holiday assignment April 2024*. Students are to submit to their respective subject teachers.

**Herr Vogel Und Frau Wal
Mr. Bird and Ms. Whale**

[click here to view the passage and video.](#) The translation is attached in.

❖ [Click here for your task.](#)

Exercise 1 10 marks



CORONA SECONDARY SCHOOL
AGBARA

END OF TERM CROSS CURRICULAR ASSIGNMENT FOR SECOND TERM, 2023/2024

CLASS: YEAR 10

Exercise 2 10 marks

Exercise 3 10 marks

Total: 30 marks

Name of teachers:

- **Jesuloba Emiola** 08138411493 Jesuloba.Emiola@coronaschools.org
- **Opemipo Arowosafe** 08131056589 Opemipo.Arowosafe@coronaschools.org

E. SUBJECT: FURTHER MATHEMATICS/GLOBAL PERSPECTIVES

Instruction: Answer the question as given in the question

Question: Topic: The impact of Mathematics on other disciplines and fields.

Prepare a questionnaire (10 questions) on Microsoft forms and share the link on social media for responses.

Prepare a graphical analysis of the responses received; using a Bar graph and a Pie chart.

Rubrics

1. Questionnaire (10 marks)
2. Graphic Analysis (10 marks)

Total: 20 marks

Names of Teachers:

- **Assumpta Eze** 08066713510 Assumpta.eze@coronaschools.org
- **Oladapo Alo** 08080297447 Oladapo.Alo@coronaschools.org

F. SUBJECT: HISTORY/CHRISTIAN RELIGIOUS STUDIES/ISLAMIC RELIGIOUS STUDIES

Instruction: Answer all questions in your test and assignment notebook.

1. What were the motivations and methods employed by Islamic scholars and European missionaries in introducing Christianity and Islam to Nigeria during the colonial era? (5 marks)

2. How did indigenous populations initially respond to the arrival of Christianity and Islam in Nigeria? (5 marks)

3. What were some of the major challenges faced by missionaries and Muslim scholars in their efforts to spread their respective religions in Nigeria? (5 marks)

4. How did the establishment of Christian missions and Muslim communities' impact local governance and social structures in Nigeria? (5 marks)

Total: 20 marks

Names of Teachers:

- **Solomon Owolabi** 08034487090 Solomon.Owolabi@coronaschools.org
- **Oluwayemisi Ajayi** 08165593892 Yemisi.Ajayi@coronaschools.org
- **Muhammed Bello** 08034788175 Muhammed.Bello@coronaschools.org